

# Precision Linear Micro-Stage

## P/N: AI-800 ME

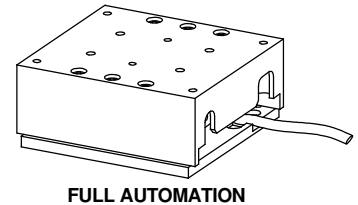
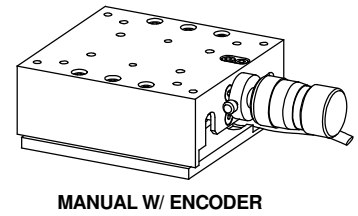
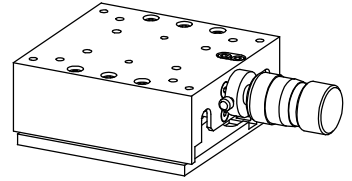
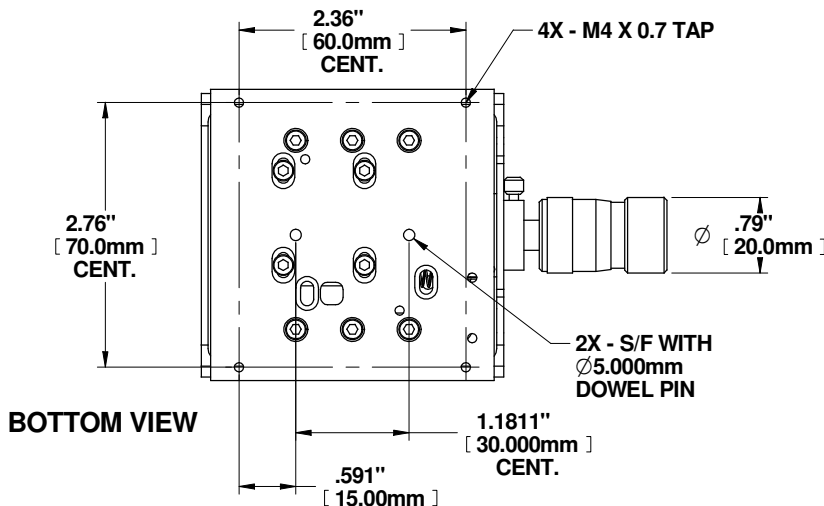
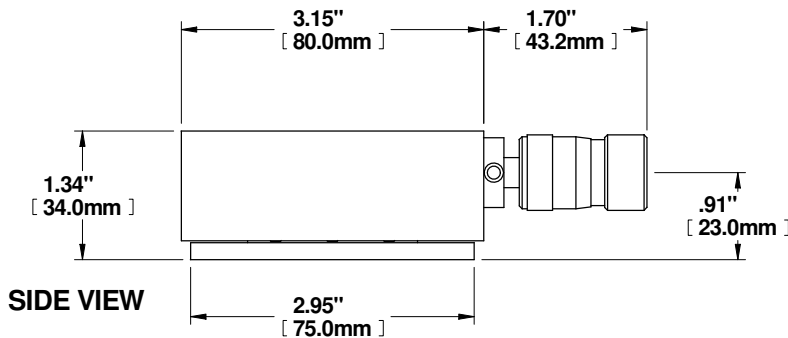
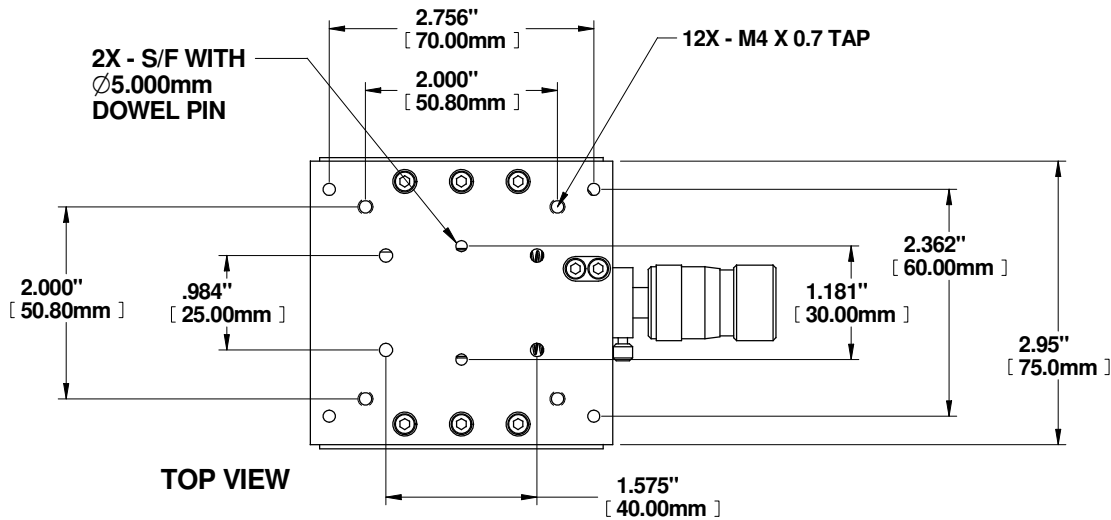

### Standard Features:

- High Precision Micrometer Driven
- 8mm Course Travel
- 1.0 Micron Course Resolution
- 0.3mm Fine Travel
- 20nm Fine Resolution
- 10 kg Load Capacity
- Designed for Automation Upgrade
- Ultra-Precision Crossed Roller Bearings
- 6061-T6 Aluminum Enclosures

### Optional Features:

- High Resolution Non-Contact Optical Linear Encoders
- Linear Piezoelectric Servo Motor
- Stainless Steel Enclosure
- Class 100 Clean Room Compatible
- Custom Designs for OEM Integration